

## SUBSTANTIATION OF THE NECESSITY AND WAYS TO IMPROVE EUROPEAN GUIDELINES FOR FIRE DETECTION AND FIRE ALARM SYSTEMS

<sup>a</sup>VOLODYMYR BOROVYKOV, <sup>b</sup>VADYM NIZHNYK,  
<sup>c</sup>OKSANA SLUTSKA, <sup>d</sup>TARAS SKOROBAGATKO,  
<sup>e</sup>VIKTOR MYKHAILOV, <sup>f</sup>DMYTRO VOYTOVYCH,  
<sup>g</sup>ROMAN SUKACH, <sup>h</sup>YAREMA VELYKYI, <sup>i</sup>VOLODYMYR-  
 PETRO PARHOMENKO, <sup>j</sup>GYEVHEN LINCHEVSKYY

<sup>a-e</sup>Institute of Public Administration and Scientific Research on  
 Civil Protection, 21, Vyshhorodska Str., 04074, Kyiv, Ukraine  
<sup>f,j</sup>Lviv State University of Life Safety, 35 Kleparivska Str., 79000,  
 Lviv, Ukraine

<sup>i</sup>Ministry of Internal Affairs of Ukraine, 10, Bohomol'tsya Str.,  
 01024, Kyiv, Ukraine

email: <sup>a</sup>foam2000@gmail.com, <sup>b</sup>nignyk@ukr.net,  
<sup>c</sup>sl\_oksi@ukr.net, <sup>d</sup>tarasskorobagatko@gmail.com,  
<sup>e</sup>mvn2006@ukr.net, <sup>f</sup>voytovych.dmt@gmail.com,  
<sup>g</sup>sukach.r@gmail.com, <sup>h</sup>yaremaVeliky@gmail.com,  
<sup>i</sup>pvpo2016@gmail.com, <sup>j</sup>leefire@ukr.net

**Abstract:** Composition, purpose, and principal functions performed by fire detection and fire alarm systems are described. The incompleteness of the information provided in the European technical specifications for the planning, design, installation, commissioning, use and maintenance of such systems (CEN/TS 54-14:2018) is indicated. A number of other documents establishing requirements on these issues valid in Europe are considered and the need to improve and expand the requirements during the development of future European standards to supersede CEN/TS 54-14:2018 are substantiated. Additions to them are proposed, in particular, an improved block diagram of the sequence of execution of the processes related to fire detection and fire alarm systems as well as an algorithm of actions aimed at reducing the frequency (probability) of false alarms formed by fire detectors. A number of issues related to the protection of premises by installation of point fire detectors under ceilings of various configurations and in certain types of special fire-hazardous premises (facilities) are identified and a solution to their protection is proposed for introducing relevant information to appropriate regulations. The necessity of conducting appropriate desk and experimental studies in order to standardize the procedure for using multi-sensor fire detectors as well as video fire detectors is substantiated. A more detailed description of the procedure for using visual alarm devices to inform people who are in a hazardous area about the occurrence of a fire is offered.

**Keywords:** fire alarm; alarm system; multi-sensor fire detectors.

### 1 Introduction

As it is known [1], the largest number of fires during which deaths, personal injuries, and burns or poisoning by gaseous combustion products take place occur just in attended buildings and structures, not outside them. At the same time, among other hazardous fire factors, the largest number of tragic cases is associated with the formation of gaseous and aerosol (smoke) volatile combustion products as well as reduced visibility due to smoke obscuration. Reduced visibility due to smoke, often combined with ignorance of the layout of the building, causes the fact that the people present do not manage to leave the hazardous area in time or leave it at all without the aid of fire and rescue services, while the latter do not always have enough time to come to the rescue at the necessary moment.

In order to start the evacuation process in the event of a fire, a person shall first learn that a fire did occur. In the absence of appropriate technical means, he (she) usually learns about a fire through his (her) own senses, for example, by seeing flames or smoke or hearing a voice message from another person. An indirect sign (but not the fact of occurrence) of a fire can also be the appearance of characteristic smells of combustion products. Unfortunately, at the moment when this happens, fire, especially in the construction facilities of a large area, with great number of floors and complex architecture, can be developed to such an extent that there is no time for a safe evacuation, or the escape routes are already blocked by smoke and/or flames.

For these reasons, building codes imply providing a number of construction facilities, depending on their type, purpose, area and other factors, with active fire protection systems, which primarily include:

- Fire detection and fire alarm systems
- Smoke and heat control systems

- Fire-fighting systems.

Namely the fire detection and fire alarm systems represent the first line of protection of people and construction facilities from hazardous factors of fire, ensuring fire detection, sending signals to trigger appropriate equipment, and informing people on the occurrence of a fire and the need to leave the hazardous area.

In Europe, a series of standards has been developed regarding fire detection and fire alarm systems as well as their components; this is *EN 54 Fire detection and fire alarm systems* which includes almost three dozen regulatory documents. The first of them (EN 54-1 [8]) regulates the terms and definitions of the main concepts as well as the functions performed by fire detection and fire alarm systems (Figure 1).

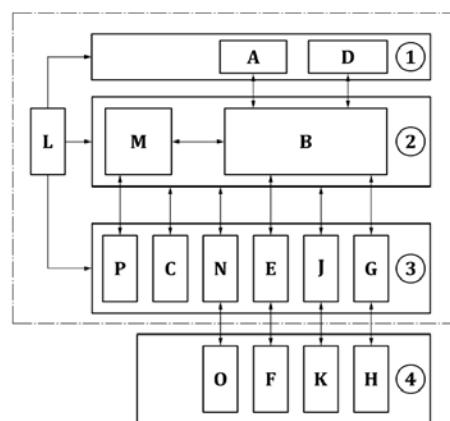

Key			
1	detection and initiating	G	fire protection control function
2	control and indicating	H	fire protection function
3	action	J	fault warning routing function
4	function associated with FDAS	K	fault warning receiving function
A	fire detection function	L	power supply function
B	control and indication function for fire detection and fire alarm	M	voice alarm control and indication function for fire alarm
C	fire alarm function (excluding loudspeaker)	N	ancillary interface function
D	manual initiating function	O	ancillary management function
E	fire alarm routing function	P	fire alarm function (loudspeakers)
F	fire alarm receiving function		← exchange of information between functions

NOTE The functions that are included within the FDAS are shown inside the dotted line.

Figure 1. Fire detection and fire alarm system and associated systems, functions, and equipment

### 2 Materials and Methods

Fire detection and fire alarm systems generally consist of a control and indicating equipment (CIE) which plays the role of a central processor, and one or more detection circuits connected to it. They connect to these circuits automatic fire detectors the task of which is to detect a fire by at least one of the factors associated with it and transmit signals to the CIE, manual call points designed to trigger the system in the event of a fire being detected by a person, alarm devices (the ones providing fire signals in a human-transparent form), and in some cases also control panels, facility layouts and auxiliary devices.

There exist manual call points and automatic fire detectors, that is, the ones automatically responding under the influence of one or more fire-related phenomena. Accordingly, automatic heat and smoke fire detectors are distinguished, as well as flame fire detectors, gas (sensitive to gaseous combustion products, most often to carbon monoxide) and combined (multi-sensor) fire detectors. Heat fire detectors respond to the release of heat and are divided into point and linear ones; the latter are heat-sensitive cables of special designs. Smoke fire detectors are point and aspirating ones; the latter are the ones to suck continuously air in the protected area and analyze it. Flame fire detectors respond to changes in the intensity of infrared and/or

ultraviolet radiation in the event of a flaming combustion. Video fire detectors capable of detecting both flame and smoke have also been developed and put into mass production in recent years.

Alarm devices can be sounders as well as visual and tactile ones and provide signals of the appropriate types informing a person about the occurrence of a fire. In addition to them, there are also voice alarm means.

Although appropriate technical requirements and test methods of the absolute majority of components of fire detection and fire alarm systems are regulated by applicable European standards, not a single regional standard for fire detection and fire alarm systems as a whole has been developed until now. European technical specifications CEN/TS 54-14:2018 [5] are currently in force, they describe the procedure for planning, design, installation, commissioning, use and maintenance of such systems. It is worth noting that before the adoption of the aforementioned document, technical specifications CEN/TS 54-14:2004 were valid, i.e., the document that superseded the 2004 edition did not acquire the status of a European standard contrary to established practice.

The reason for this phenomenon is that the members of the relevant European standardization committee (TC 72 "Fire Detection and Fire Alarm Systems") did not reach a consensus regarding the provisions of the relevant standard. This is easily explained by the significant differences in the national building codes of various European countries, the peculiarities of industrial production in them, different established practices and even different traditions that have developed historically, not to mention climatic factors and the specifics of provision of buildings, structures and premises with heat, ventilation and air conditioning equipment as well as thermal insulation. It is not surprising that the approaches used in the countries of Southern Europe are of little use in the countries of Scandinavia, and vice versa.

It is worth noting that reaching a consensus even at the level of technical specifications (and, even more so, a standard) can mean removing part of the provisions of each of the clauses of the document which were initially proposed by the first-hand developer. That is why standardization at the regional level does not usually provide such a detailed description of the requirements as it can be in the case of the corresponding national standard. In view of this, it does not seem surprising that it is stated in the technical specifications CEN/TS 54-14 [5] that "This document is intended as a template to be used in the drafting, review, and revision of any national standards and guidelines".

One of clear examples of how detailed national regulations can be is the existence of the British standards for fire detection and fire alarm systems BS 5839-1:2017 [3] and BS 5839-6:2019+A2:2020 [4] which contain more detailed provisions than [5]. They were prepared and focused primarily on compliance with the requirements of appropriate national standards, and numerous detailed comments were also submitted to a number of sections and clauses.

Incompleteness and, in the opinion of some experts, insufficient rigidity of the requirements of CEN/TS 54-14 [5] also led to the appearance of regulatory documents regarding fire detection and fire alarm systems developed by European insurance companies, in particular, VdS 2095:2022-06 [6] and SEA 4040:2003 [7].

At the same time, it should be noted that in the available literature (apart from frankly outdated sources) there is actually no data that is or could be the basis for the development of the provisions of both the currently valid European technical specifications and the guidelines of European insurance companies, for instance, those regarding the regulation of the placement of fire detectors depending on their types, as well as the specifics of the protected premises and facilities. This fact is explained by that the development of components of fire detection and fire alarm systems, regulatory documents

regarding them, and procedure for their use as part of fire detection and fire alarm systems in Europe is almost exclusively carried out by their manufacturers who prefer not to disclose information that could be useful to their competitors. Finally, technologies in the field of fire detectors and alarm devices are developing, new designs of them are appearing, and specifics of application and limitations are being determined more exactly. The same applies to the main and auxiliary equipment of fire detection and fire alarm systems, electrical cables, etc. Accordingly, provisions of documents like CEN/TS 54-14, development of which lasts quite a long time and during which additional changes in conception and technology may occur a priori, cannot correspond to the latest achievements in the relevant sphere.

The purpose of the work was analytical research of existing technical specifications, guidelines, standards as well as practical experience of their application in Ukraine in order to justify amendments and additions to technical specifications CEN/TS 54-14 [5] for their future acquisition of the status of a European standard.

### 3 Results and Discussion

Analyzing normative documents and guidelines for the planning of fire detection and fire alarm systems, as well as the experience of using them made it possible to determine the priority trends for the correction of the CEN/TS 54-14 [5] guidelines with the aim of transforming them into a European standard in the future. The main results are as follows.

Perhaps the most remarkable feature of CEN/TS 54-14 [5] is the thesis presented in clause 4.1, namely that the document contains recommendations that are not mandatory, but "provide a suitable basis for the provision and usage of good systems". It is because of this the fact that building codes and other regulatory documents in force in different countries differ significantly, as well as the imposition by CEN/TS 54-14 [5] significant responsibility on the system designer, appropriate authorities having jurisdiction and insurance companies, the mentioned document establishes only a general algorithm (block diagram) of the sequence of execution of processes related to the "idealized" system (Figure 2).

Unfortunately, the block diagram provided by CEN/TS 54-14 [5] does not give an answer to the question of who exactly should perform certain stages related to the planning, designing of the system, its commissioning and putting into operation, as well as use and periodic inspection of its functionality. It is also unclear how to document all these operations. At the same time, analyzing of the provisions of the document allowed the authors of this paper to propose an algorithm of actions that can eliminate these shortcomings and can be suitable for use in different countries despite the differences in their current legal framework (Figure 3).

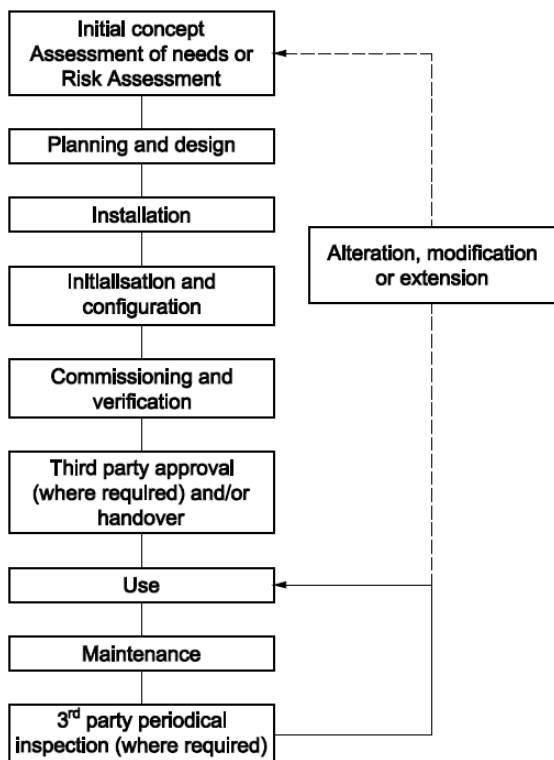

Figure 2. Block diagram of the sequence of execution of processes related to an idealized system (according to [5])

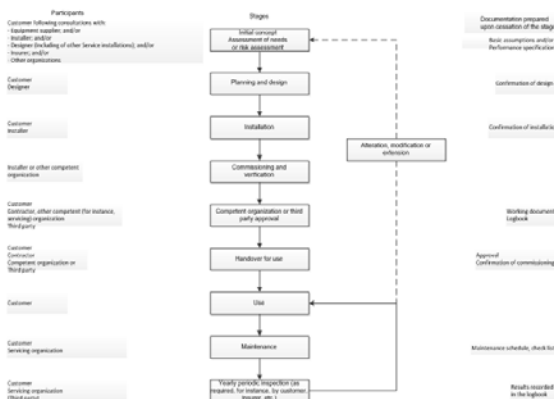

Figure 3. Proposed block diagram of the sequence of execution of processes related to a fire detection and fire alarm system

Although such issues as the assessment of the requirements for the system, the principles of its planning with a view to ensuring maximum functionality and minimizing the number of false alarms as well as the completeness of the protection of the premises of the facilities are generally clear and do not cause significant disagreements between the designers of the system, specifics of the protection of individual types of premises, especially in the presence of certain types of ceiling structures, is associated with numerous ambiguities. Thus, for example, CEN/TS 54-14 [5] provides for the division of the building into fire detection zones and fire alarm zones, the boundaries of which shall meet the requirements established by the sequence of actions in the event of a fire alarm signal. At the same time, the area of a separate zone should not exceed 2,000 m<sup>2</sup>, nor should it contain more than 32 point fire detectors, or the search distance in it, measured from the point of entry to the zone, should not be more than 60 m (clause 6.3.2 b)).

Namely the wording of the last provision is often the cause of misunderstanding of this requirement by persons involved in the design of fire detection and fire alarm systems. Considering what document [5] implies in this concept (the distance that shall be covered by the personnel on duty within the fire detection zone to determine visually the location of the fire source), it would be advisable to add illustrative material to this clause, for example, such as the one provided in British regulations [5] (Figure 4).

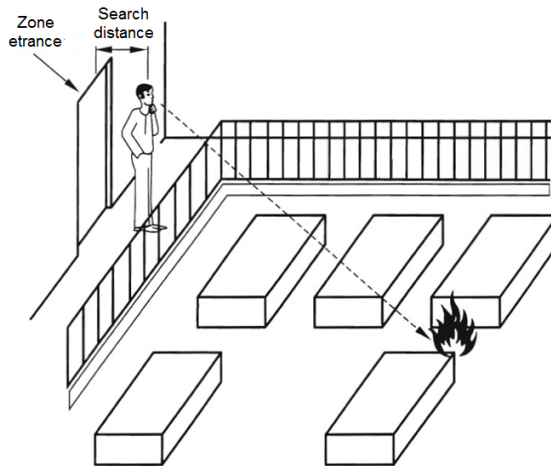

Figure 4. Search distance

It should also be noted that the search distance can depend to a large extent not only on the configuration and purpose of the premises but also on the available furniture and other objects that may become obstacles to the detection of fire sources. That is why this point shall be described in the regulations which will be developed in the future to replace CEN/TS 54-14 [5]. In other words, in addition to the already existing requirements for verifying the invariance of the configuration of the protected premises during periodic inspections of the system, it is necessary to introduce the requirement on that the planning of the system in terms of compliance with the requirements for the maximum search distance should be carried out exclusively after determining the locations of furniture, stored products, and/or processing equipment.

The practice of applying CEN/TS 54-14 [5] also shows that the information provided in clause 6.4.2 often does not allow designers to realize the fundamental differences in the capabilities provided by aspirating smoke fire detectors, which fundamentally differ from point fire detectors of all the known types. The same applies to the selection of categories of systems with aspirating smoke detectors by sensitivity. However, the answers to these questions are given by the guidelines [8], the provisions of which could be taken as a basis during the future correction of CEN/TS 54-14 [5]. In particular, other things being equal, aspirating smoke fire detectors differ from smoke fire detectors of other types by:

- Very early detection of fire in premises with intense air flows (e.g. data centres), i.e., detecting it before point smoke detectors or linear beam smoke detectors can respond
- Increased sensitivity to smoke (for example, in premises with very high ceilings where intensive dilution of smoke with air takes place) or an earlier sending of the alarm signal.
- The category of systems with aspirating smoke fire detectors is selected taking into account:
  - Class of fire detector
  - Air sampling technique or method
  - Method of ensuring compliance (fulfillment of mandatory requirements or its achievement by ensuring certain performance)
- Motives that led to the choice of aspirating smoke fire detectors.

Aspirating smoke detectors are an alternative to point smoke detectors and linear beam smoke detectors for a number of reasons, including greater accessibility for maintenance, the possibility of use to compensate for deviations from building codes, efficiency of fire detection in the event of heavy smoke dispersion, and the possibility of use in the presence of obstacles that make it impossible to use beam smoke fire detectors. The absence of this information in the current European guidelines [5] limits the use of the described advanced technologies. This is one of the reasons for the slow introduction of aspirating fire detectors into the practice of fire protection of warehouses with high-rack storage of products as well as premises for data processing.

However, the largest number of questions arises namely regarding the placement of automatic fire detectors and manual call points. The general and completely logical principle [5] is that manual call points should be located in places where they can be easily used by persons who have detected signs of fire, and automatic fire detectors should be installed in places where the influence of volatile combustion products or other fire factors on their sensors will cause responding of the fire detection system (i.e. fire detection) as early as possible. Taking into account the fact that hot gaseous and aerosol combustion products under the influence of buoyant force accumulate mainly under the ceiling or roof of the building, heat and smoke fire detectors are placed mainly under these structures at a certain distance from them.

Although the issues related to the placement of fire detectors under flat ceilings (roofs) are generally clear, their placement under ceilings (roofs) with a slope or of other shapes is not regulated clearly enough. Thus, according to CEN/TS 54-14 [5], clause 6.5.1 b), "If the difference in height between the bottom of the pitched roof and the top of the apex is less than 600 mm then the roof may be treated as if it were flat if smoke detectors are used. If the protected space has a north-light (sawtooth) roof then detectors should be installed within sawtooth on the sloping part of the sawtooth at a vertical distance of 1,0 m from the highest point of the sawtooth".

As experience shows, such wording confuses not only ordinary designers, but also experts who are engaged in checking the correctness of developed system designs as well as employees of relevant authorities having jurisdiction. When searching for a way out of this situation, the authors focused on the fact that the sensor of any fire detector should respond as early as possible in the event of a fire. And although no results of relevant studies were found in the available scientific literature, the guidelines VdS 2095 [10] provide a fairly clear answer to these questions: the document recommends the use of point smoke fire detectors in such cases.

Analyzing the distances between fire detector sensors and the ceilings recommended by it allows concluding that the document envisages the application of the principle of ensuring the earliest possible detection of fire signs. The corresponding layouts are shown in Figure 5. The values of the unspecified distances are set by the aforementioned guidelines depending on the ceiling parameters. In our opinion, introduction of such illustrative material together with the corresponding numerical values in the document which will be developed to supersede CEN/TS 54-14 [5] will make it possible to avoid numerous problems with the protection of facilities with ceilings and roofs of such shapes.

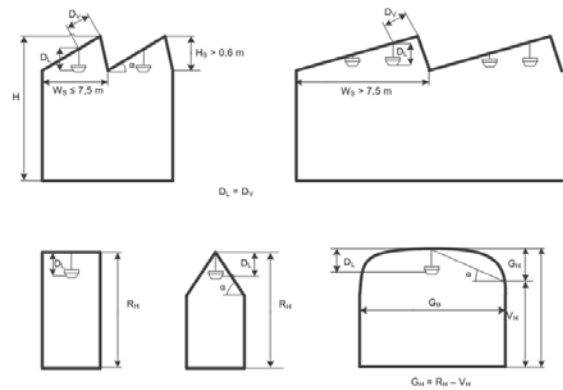

Figure 5. Placement and spacing of point smoke fire detectors for different forms of ceilings and coatings (depicted according to data [10])

It is quite clear that the movement of smoke, gaseous combustion products, and heat flows is affected by building structures, especially those located in the upper part of the premises, processing equipment, stored products, and service installations. That is why CEN/TS 54-14 [5] provides for the normalization of the spacing between them and walls and partitions, between the fire detectors themselves, as well as the presence of a free space under them of at least 500 mm (see the example given in Figure 6).

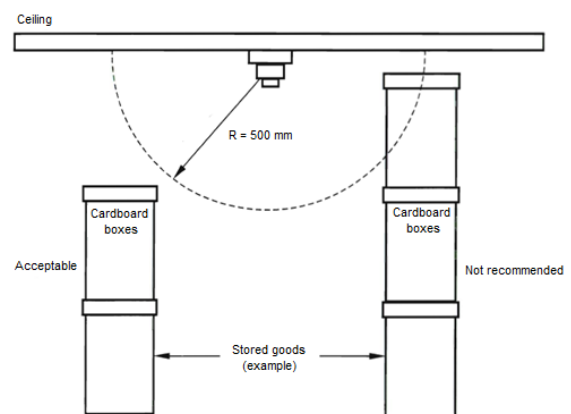

Figure 6. Free space below fire detector [2]

On the other hand, European guidelines [3] do not provide answers to questions regarding the placement of point fire detectors in relation to lighting fittings and other means and obstacles that may be present on the ceiling or near it. This issue is not trivial because the very lighting fittings, especially when using incandescent lamps, can cause false responding of heat fire detectors, and, for instance, racks in warehouses can become obstacles to the movement of smoke, heat and gaseous combustion products, making responding of point fire detectors impossible or causing them to respond in places remote from the place of occurrence of the fire. Appropriate recommendations in the future could be taken from British standard BS 5839-1 [2] (Figures 7 and 8). In the latter case, storage racks are considered as walls that reach the ceiling, and fire detectors are placed based particularly on such considerations.

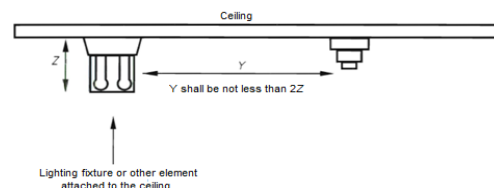

Figure 7. Placement of point fire detectors relative to ceiling fixtures

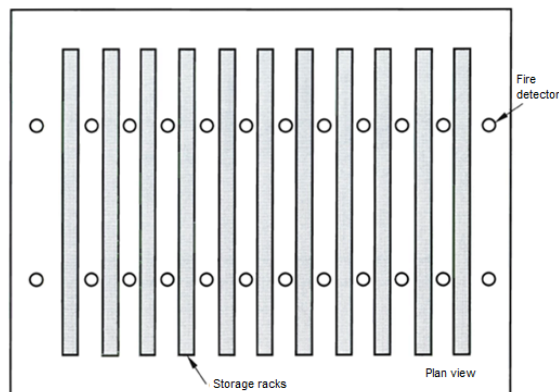

Figure 8. Placement of fire detectors in case of availability of partitions or storage racks whose upper edge is located less than 300 mm from the ceiling

Difficulties often arise due to a lack of understanding of the specifics of placing point fire detectors on uneven ceilings, which, in our opinion, is also due to the vagueness of the wording in CEN/TS 54-14 [5], in particular, in clause 6.5.1 f). However, the need to take into account ceiling beams or other obstacles during their placement can be clearly illustrated by Figure 9 [4].

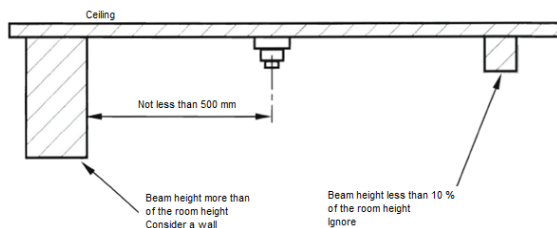

Figure 9. Placement of fire detectors in case of availability of ceiling obstacles

There are even greater difficulties in understanding how to protect honeycomb ceilings. In particular, it is stated: "If the ceiling arrangement is such as to form a series of small cells (as in a honeycomb), then, within the radius limits of Table 1, a single point-type detector may cover a group of cells. The internal volume of the cells covered by a single detector should not exceed:

$$\text{For heat detectors: } V = 6 \text{ m}^2 \times (H - h)$$

$$\text{For smoke detectors: } V = 12 \text{ m}^2 \times (H - h),$$

Where  $H$  is the height of the ceiling (or cavity),  $m$ ,  $h$  is the depth of the beam,  $m$ ."

In addition to considerable imagination, the fulfilment of this requirement is related to the question: where exactly should the fire detector be installed: at the lower edge of the beam or on the ceiling itself? To answer this question, it is necessary to remember again the purpose of a point fire detector – to detect a fire at the earliest possible stage. In view of this, a logical conclusion is suggested that fire detectors should be installed on the ceiling within each cell, but in this case, dilemmas arise related to the technical and economic feasibility of such a solution because the area of the cell can be as small as a few tenths of a square metre.

In our opinion, the best solution in such a case is the approach regulated by BS 5839-1 [2] (Figure 10).

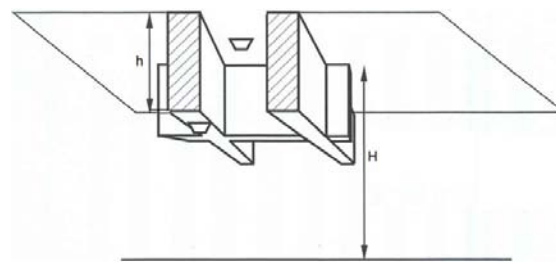

Figure 10. Placement of fire detectors on a ceiling with honeycombs

As is seen, fire detectors can be installed both on the ceiling inside the honeycomb and on the partitions used for the division into honeycombs. If the designer of the fire detection system suggests that the volume of the honeycombs is large enough to make it economically justifiable to equip each of them with a fire detector, then he (she) can foresee just such a solution. Otherwise, fire detectors are allowed to be installed on the very partitions between the honeycombs in such a way that the above-mentioned conditions regarding the maximum total volume of the honeycombs protected by each of them are fulfilled. In the latter case, when the honeycombs have a small area and, accordingly, volume, hot gaseous combustion products and smoke fill those of them which are located directly above the fire source quite quickly, after which the flow of smoke and hot gaseous combustion products into the neighbouring ones begins with their passage under partitions between the honeycombs on which fire detectors are installed. Responding of fire detectors in this case can be achieved in acceptable periods of time. At the same time, as the ceiling height increases, the width of the plume of smoke and/or gaseous combustion products increases as it rises, i.e., the probability that the space of only one honeycomb will be filled initially without affecting the fire detector installed nearby on the partition decreases. Accordingly, the probability of responding of this detector increases.

However, in our opinion, the evaluation of the effectiveness and acceptability of decisions regarding the protection of premises with ceilings of a similar structure should be made separately in each specific case taking into account local conditions and based on the results of risk assessment; this should be specified in the future standard for fire detection and fire alarm systems. In general, it would be more correct to conduct a series of experimental studies that should give a clearer answer to the question.

Unfortunately, CEN/TS 54-14 [5] pays too little attention to the protection of so-called special fire-hazardous facilities, in particular, rooms for electronic data processing. This document indicates that a number of aspects need to be taken into account when designing fire alarm systems for premises containing electronic equipment such as computers or switching telephone equipment. These include the impact on the system operation of the intensive ventilation and the high speed of air flows, the need to detect fire in hidden spaces, such as spaces above suspended ceilings and under false floors, the presence of air flows inside such spaces, the presence of devices for controlling ventilation and air conditioning systems, closing of fire dampers in response to signals from the fire detection system as well as the presence of devices for changing the mode of operation of air handling equipment in the event of a fire. It is noted that this may require special types of fire detectors (in particular, aspirating smoke detectors), especially where local protection is provided for server racks, air handling equipment return grilles, etc. More detailed information regarding the selection of types and placement of point fire detectors depending on these aspects is provided, in particular, in the guidelines [4] which describe the relevant requirements and provide a large number of illustrative materials that could be taken as a basis during future developments.

It is also worth noting that in recent years a number of models of video fire detectors have been developed in the world as well as

international technical specifications for them [9]. To date, the possibility and order of their use are not standardized by the European technical specifications CEN/TS 54-14 [5], and this shortcoming will certainly need to be eliminated in the future during the development of the relevant regulations. In addition, despite the provision in the document of fragmentary information on multi-sensor fire detectors, it does not provide answers to numerous questions related to the cases when their use is most appropriate depending on which sensors are included in them. This is partly due to the fact that the world currently has not accumulated "huge" experience of their use as well as effectiveness during the detection of real fires. Accordingly, further statistical data collection and probably experimental studies are needed.

Perhaps the most important task of fire detection and fire alarm systems is to provide a fire signal in a form that is understandable to a person. For this purpose, as part of the system, as a rule, sounders or visual fire alarms are used as well as voice alarm devices, for which there are separate regulations [6]. And although the document [5] quite clearly describes the requirements for the installation and sound volume levels of sounders, in our opinion, there is not enough information (clause 6.6.3) on visual fire alarms. At the same time, analyzing of provisions of [2-4, 10] as well as logical considerations make it possible to formulate the following recommendations regarding them:

- Sounders should be provided in premises where background noise levels exceed 90 dB(A) as well as in ones where people can normally use hearing protection devices
- Visual fire alarm devices should be provided in sufficient numbers and located within the premises in such a way that they can be easily seen from all points to which people normally have access under normal levels of background illumination
- Visual fire alarm devices should flash with a frequency of 30 to 130 flashes per minute
- The signals from visual fire alarm devices should be such that they can be easily distinguished from other visual signals provided on the facility; it is desirable that their color be red
- The luminous intensity at the outputs of visual fire alarm devices should be sufficient to attract attention, but not so high as to cause a reduction in visibility due to excessive brightness
- Visual fire alarm devices should be installed at a height not less than 2.1 m.

Finally, it remains to say that one of the most significant problems associated with the operation of fire detection and fire alarm systems is the formation of false alarm signals by them. The most common causes of their occurrence include [5]:

- Work being carried out in a protected area without knowledge of, or in neglect of, the necessary precautions such as disabling detectors
- Ambient conditions such as heat, smoke, flame, steam or dust from cooking or work processes or fumes from engine exhaust
- Mechanical and electrical faults, often resulting from the effects of vibration, impact or corrosion
- Servicing or testing work carried out without prior notification to the fire brigade or central alarm station
- Electrical transients (such as from lightning or switch-on surges) or radio interference
- Inadequate servicing
- Build-up of dust or dirt within a detector, or the entry of insects
- Change of use or changes within the building without appropriate changes to the fire detection and alarm system
- Accidental or malicious operation of manual or automatic fire detectors.

In addition to this description, guidelines CEN/TS 54-14 [5] contain information on the vulnerability of fire detectors of various types as well as certain recommendations for reducing the probability of false alarms. At the same time, the document does not establish a single algorithm of actions of interested parties, primarily designers, aimed at reducing the number/frequency of false alarm signals by fire detection systems.

At the same time, systematization of available information makes it possible to form a single algorithm (block diagram) of actions aimed at achieving this goal (Figure 11), which could also become part of the future European standard for the planning, design, installation, commissioning, operation and maintenance of fire detection and fire alarm systems.

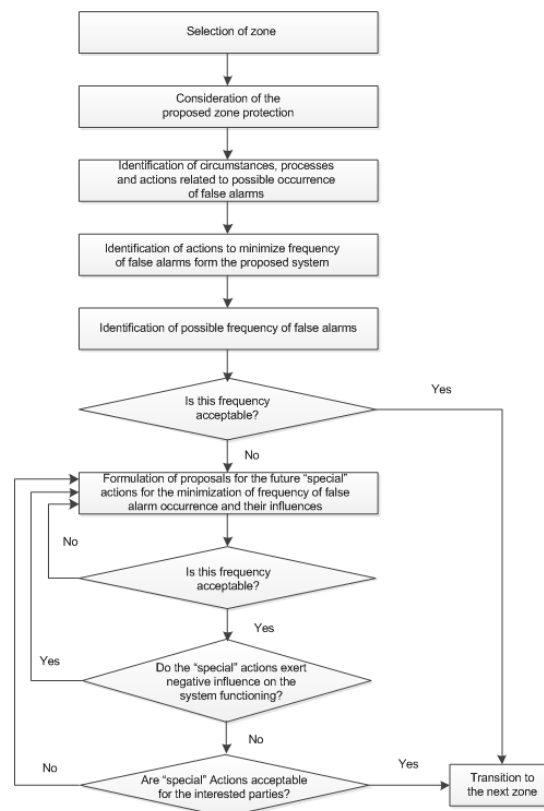

Figure 11. Block diagram of actions aimed at limiting the frequency of false alarms

#### 4 Conclusion

Thus, as a result of the desk studies, the necessity of amending and correcting CEN/TS 54-14:2018 [5] was substantiated by introducing the following amendments, including an increase in the amount of illustrative material:

1. A detailed interpretation of the algorithm of actions during the planning, designing, installation, commissioning, use and maintenance of fire detection and fire alarm systems while indicating the responsible persons and relevant documents. Such an interpretation in the regulations to be prepared in the future is proposed to be presented in the form of a block diagram developed by the authors.
2. Clarifying the procedure for determining the search distance, the procedure for using point fire detectors to protect honeycomb ceilings as well as their installation under ceilings and roofs of special geometric shapes (oval, pointed, inclined ones). It is proposed to make such a clarification based on the logical considerations described above and examples of the implementation of requirements for the protection of relevant premises and building structures, given in the guidelines of the European societies

of insurance companies as well as national standards of individual countries.

3. Clearer regulation of the procedure for using point fire detectors depending on existing obstacles (building structures, service installations, processing equipment, furniture) as well as the purpose of facilities/premises, characteristics of air flows, etc.; provision of more detailed information on the use of multi-sensor fire detectors as well as information on the procedure for using video fire detectors.
4. Addition of information on the use of aspirating smoke fire detectors for the protection of facilities such as warehouses with high-rack storage of products, data processing centres, production shops, public facilities with high ceilings (including buildings with an atrium), etc. As a basis for this purpose, it is proposed to take the guidelines [8] with mandatory consideration of the requirements for the sensitivity classes of such detectors for each type of use.
5. Systematization of data on the causes of false alarms, vulnerability of fire detectors of various types to the causes of their occurrence, as well as measures to prevent the occurrence of such alarms with the provision of the block diagram of actions proposed by the authors in order to limit the frequency of false alarms.

#### Literature:

1. Analytical material. <https://idundcz.dsns.gov.ua/statistika-pozhezh/analitichni-materiali>.
2. BS 5839-1:2017 Fire detection and fire alarm systems for buildings. Code of practice for design, installation, commissioning and maintenance of systems in non-domestic premises.
3. BS 5839-6:2019+A1:2020 Fire detection and fire alarm systems for buildings. Code of practice for design, installation, commissioning and maintenance of systems in domestic premises
4. CEA 4040:2003 Planning and Installation for Automatic Fire Detection and Fire Alarm Systems.
5. CEN/TS 54-14:2018 Fire detection and fire alarm systems – Part 14: Guidelines for planning, design, installation, commissioning, use and maintenance
6. CEN/TS 54-32:2015 Fire detection and fire alarm systems – Part 32: Planning, design, installation, commissioning, use and maintenance of voice alarm systems.
7. Design, Installation, Commissioning and Maintenance of Aspirating Smoke Detector (ASD) Systems / Fire Industry Association. <https://www.fia.uk.com/static/uploaded/440ce5b2-6824-4fdb-ab20a887f80722d6.pdf>
8. EN 54-1:2021 Fire detection and fire alarm systems – Part 1: Introduction.
9. ISO/TS 7240-29:2017 Fire detection and alarm systems – Part 29: Video fire detectors
10. VdS 2095:2022-06 Fire detection/alarm systems – Planning and Installation.

**Primary Paper Section: J**

**Secondary Paper Section: JB, JN, AQ**