



jet.com.ua

EASTERN-EUROPEAN JOURNAL OF ENTERPRISE TECHNOLOGIES

ISSN 1729-3774



информационные технологии

інформаційні технології

information
technologies

5/5 (95)
2018

Новая экономика

нова економіка

промышленные технологии

промислові технології

industrial
applications

- Applied physics

5/5 (95) 2018 Content

APPLIED PHYSICS

- 6 Development of the technique for improving the structure of a magnetic field in the aperture of a quadrupole electromagnet with a superconducting winding
A. Getman
- 13 Development of the method to operatively control quality of iron ore raw materials at open and underground extraction
A. Azaryan, A. Gritsenko, A. Trachuk, D. Shvets
- 20 Improvement of safety of autonomous electrical installations by implementing a method for calculating the electrolytic grounding electrodes parameters
P. Budanov, K. Brovko, A. Cherniuk, I. Pantjelleeva, Yu. Oliynyk, N. Shmatko, P. Vasyuchenko
- 29 Determination of optimal parameters of the pulse width modulation of the 4qs transducer for electric rolling stock
O. Demydov, B. Liubarskyi, V. Domanskyi, M. Glebova, D. Iakunin, A. Tyshchenko
- 39 Studying the computational resource demands of mathematical models for moving surface eddy current probes for synthesis problems
R. Trembovetska, V. Halchenko, V. Tychkov
- 47 Construction of the integrated method to model a system for measuring the density of infrared radiation flows
A. Sytnik, I. Semko, V. Tkachenko, K. Klyuchka, S. Protasov
- 53 Welded joints geometry testing by means of automated structured light scanning
G. Filippov, D. Sednev, Y. Salchak
- 61 Developing and programming the algorithm of refinement of the crystal structure of materials with possible isomorphous substitution
I. Yaremly, S. Yaremly, V. Fedoriv, O. Vlasil, A. Lucas
- 68 Improvement of a discharge nozzle damping attachment to suppress fires of class D
V. Kovalyshyn, V. Marych, Y. Novitskyi, B. Gusar, V. Chernetskiy, O. Mirus
- 77 Abstracts & References

Для дослідження насадки-заспокоювача використаний програмний продукт *COSMOSFloWorks*. Запропонована методика оцінювання потрапляння вогнегасного порошку на поверхню, деко розмірами $0.4 \times 0,4$ м. Встановлено, що існуючі насадки-заспокоювачі не є ефективними тому, що при гасінні легких металів не достатньо зменшують швидкість подачі порошку на горючу поверхню і роздмухують вогонь, рівномірно не покривають вогнегасним порошком поверхню горіння. Після гасіння на поверхні вкритою порошком утворюються прогари. Змодельовано оптимальні конструкційні параметри насадки-заспокоювача для гасіння пожеж класу D у вигляді насадки-заспокоювача з еліптичним верхом та параболічним відбивачем. Доведено, що заспокоювач з двома робочими поверхнями ефективніший від попереднього заспокоювача з одною робочою поверхнею на 30 %. Завдяки цьому вогнегасний порошок покриває більшим шаром поверхню горіння, не роздмухуючи стружку з поверхні горючого металу, тим самим зменшується час гасіння та збільшується ефективність подачі вогнегасного порошку. Експериментальними дослідженнями підтверджено, що використання заспокоювача для подачі вогнегасного порошку з двома робочими поверхнями для гасіння пожеж класу D, збільшує потрапляння порошку на об'єкт гасіння та становить більше 90 %.

Визначено діаметр насадки та її форма. Насадка повинна бути у вигляді дифузора з діаметром 16 мм.

Розробка може використовуватися при створенні стаціонарних та переносних систем пожежогасіння для гасіння легких металів та сплавів, в тому числі і запалювальних гранат при умові правильного підбору порошку. Досягнуто позитивних результатів під час проведення полігонних випробувань насадки-заспокоювача на макетному вогнищі при горінні стружки сплавів магнію.

Ключові слова: насадка-заспокоювач, пожежі легких металів, гасіння пожежі магнію, оптимальний тиск, оптимальна відстань

1. Introduction

The most dangerous fire- and explosive metals whose burning relates to class D are light metals in the form of processed products: powders of different dispersity, shavings. Metals in the form of articles of various configurations (sheets, profiles, etc.) are almost impossible to ignite if the conditions are met on that heat removal prevails over heating.

We shall analyze the most resonant fires of class D, caused by the presence of magnesium alloys [1].

The fire of magnesium chips in October, 2006 started in a container for metal waste at the territory of Lviv bus plant (Ukraine). The cause of the fire was the ignition of a container with magnesium chips. No one was hurt during

the fire, but there was a danger to the health of Lviv citizens since the container was placed near a trolleybus stop. Extinguishing the fire lasted for several hours because magnesium cannot be extinguished with water, and the means that were available did not make it possible to do it quickly. In Crimea, on October, 17, 2009, a fire started at a depo that stored poisonous chemicals ("Otradnoye", Dzhankoy region). The resulting fire burned about 160 tons of poisonous chemicals. The area of the fire was about 600 square meters. The depo had stored magnesium-containing pesticides since 1960s–1970s. According to one explanation, it is the magnesium that caused a spontaneous combustion of pesticides.

In April 2010, a powerful explosion took place at the plant "Kyivprylad" (Ukraine), Garmatna Street, 2, Solo-

UDC 614.8

DOI: 10.15587/1729-4061.2018.144874

IMPROVEMENT OF A DISCHARGE NOZZLE DAMPING ATTACHMENT TO SUPPRESS FIRES OF CLASS D

V. Kovalyshyn

Doctor of Technical Sciences,
Professor, Head of Department*
E-mail: kovalyshyn.v@gmail.com

V. Marych

Adjunct
Department of Industrial and Occupational Safety**
E-mail: marychvolodj@ukr.net

Y. Novitskyi

PhD, Associate Professor
Department of Technical Mechanics
and Machine Dynamics
Lviv Polytechnic National University
S. Bandera str., 12, Lviv, Ukraine, 79000
E-mail: yarnovitsky@gmail.com

B. Gusar

Adjunct*
E-mail: bogdan.gusar.94@gmail.com

V. Chernetskiy

PhD, Head of Department
Department of the State Emergency Service
Franka str., 6, Ivano-Frankivsk, Ukraine, 76018
E-mail: chernetskiy.volodymyr@gmail.com

O. Mirus

PhD, Head of Department
Department of Industrial and Occupational Safety**

E-mail: mirus@ukr.net
*Department of Emergencies Recovery
**Lviv State University of Life Safety

Kleparivska str., 35, Lviv, Ukraine, 79007

menskiy district. The cause of the explosion was a spark from the gas-welding machine, which happened to be in a container with magnesium, the result of the explosion is the two killed persons. The high temperature melted metal structures of an elevator, and the flash blew out glass in the workshop from the ground floor up to the third floor.

On February 17, 2016, explosions at an ammunition depot in Zaporozhye (Ukraine) started a fire at the territory of military warehouses. Unidentified persons that used unmanned aircraft dropped flammable items into the object. The result of their explosion was the fire sites, which were difficult to extinguish. Separate particles of magnesium got under wooden boxes that stored ammunition. It was impossible to use water for suppressing the fire because it is ineffective at extinguishing these metals. The primary means of fire suppression, fire extinguishers, are filled with specialized powders although the discharge nozzles damping attachments are missing. The anti-fire tank and soil were used. There were about 50 fire sites on record.

On April 2, 2008, two fires took place at VAT "Magnitogorsk iron and steel works" (Russia) on the same day. After the arrival of the first squad it was discovered that granulated magnesium was on fire in an open area of 20 square meters. The resulting fire destroyed six tons of magnesium.

On October 2, 2015, more than 20 firefighters were suppressing 47 tons of burning magnesium at plant PolMag in the city of Olszowej, Poland. The first stage involved efforts to suppress burning of molten magnesium alloy, to no avail. They applied a fire-extinguishing powder, but the fire was so intense that it was impossible to put out. The lacked the necessary means to feed the fire-extinguishing substances [2].

Burning of magnesium in 2010 in Sonneberg [3] inflicted losses worth millions of euros after 30 tons of magnesium were burnt. The localization and suppression of the fire took longer than it was required as there were no effective means of initial fire extinguishing.

The features of light metals, which are directly related to fire- and explosive dangers, include the following: capability to explode in the state of an aerosol; the interaction between burning metals and water and certain gas fire-extinguishing compounds: chloradones (chlorofluorocarbons), nitrogen, carbon dioxide (for example, magnesium), and others [4, 5].

A self-ignition temperature of magnesium is: for compact metal, +650 °C, for chips, 510 °C; for dust, 420...440 °C. Melting point is 651 °C. Boiling point is 1,090 °C. It can ignite in the open air; in the humid environment it burns with an explosion. The temperature of burning exceeds 2000 °C. When interacting with water, it emits flammable gases and a large amount of heat [5].

Fires that involve the burning of light metals, including magnesium, happen quite often in Ukraine and abroad. Recently, sports fans have used compounds of magnesium in the manufacture of the so-called fiers. Ukraine does not produce any fire-extinguishing devices for the extinguishing of fires of class D.

Fires of light metals, including magnesium, are suppressed by covering a burning surface with a special fire-extinguishing powder and by insulating a combustible metal, thereby making it impossible for the fire to propagate at the surface. In order to guide the powder to the burning surface under high pressure in the body of a fire-extinguishing device, preventing the fanning of a fire site, different types of discharge nozzle damping attachments are applied [1, 6, 7]. Their disadvantage is the small amount of the powder, which

lands at the burning surface and high pressure at the outlet from the nozzle.

A powder that exits the attachment should evenly cover a burning surface and should not leave the attachment at a great speed as this would lead to spreading the powder resulting in fanning the combustion and enlarging the combustion area. It all relates to the shortcomings of discharge nozzle damping attachments that are used to extinguish the fires of light metals. All damping attachments or techniques to feed the powder used earlier reached a 70 % penetration of powder at the surface, which increased the duration of fire extinguishing, reduced the intensity of fire extinguishing, sometimes a fire was not suppressed at all. When studying the movement of the powder, one should take into consideration that it involves not only the motion of solid particles, but the movement of gas and a fire-extinguishing powder. The speed of particle motion reduces not only due to the repulsion from a parabolic surface. In Ukraine, there is no commercial production of discharge nozzle damping attachments to suppress fires of class D.

2. Literature review and problem statement

The fire extinguishing of light metals requires appropriate extinguishing agents and the means of their feed. When putting out light metals, it is necessary to feed the powder at a minimum motion speed of its particles towards a burning surface, so that it covers the surface and does not fan the fire. Many researchers investigated fire-extinguishing agents to suppress fires of class D. Studies into fire suppression with fire-extinguishing powders of special purpose were reported in [2, 3, 6]. In all cases, the researchers concluded that the composition of specialized powders should include NaCl, KCl. Sand powder, slag, ash, compounds of melamine, graphite, kaolin clay could act as fillers.

Paper [8] suggests extinguishing magnesium by argon. This is justified only in closed volumes. The extinguishing by argon and aerosols is the volumetric technique of suppression, which works out poorly at surface suppression [8, 9]. Burning slows down but it does not stop completely.

Authors of [9–11] used attachments in the form of a nozzle or a direct attachment that does not help further reduce the motion speed of the powder. The proposed fire extinguishing substances have proven ineffective in the practice of extinguishing the light metals as there is an additional issue of feeding a fire-extinguishing substance in a certain direction.

In the cases when attachments in the form of a nozzle were used for fire extinguishing using the method of insulation, it was impossible to cover the surface; in addition, shavings spread thereby fanning the fire. Therefore, it is required that a powder should be gently spread over a burning surface under pressure not exceeding 0.01 MPa. Known procedure [7, 12] implies feeding the powder using an L-shaped attachment; the powder is repulsed from the bottom of the half-cylinder. The damping attachment employs a single parabolic surface, which makes it possible to reduce the motion speed of the powder particles and ensures its scattering over the surface. A variant from [12, 13] applies a side pipeline on which the powder partially settles.

The Canadians [14] use direct nozzle attachments, which have a jet crusher inside. A powder leaves through many nozzles; it increases resistance that decreases the motion speed of the powder from the outlet. The amount

of powder that gets into the burning zone is 65–67 %; this, however, is not enough.

Authors of [7] apply and describe the one-side and elliptical ejectors whose percentage of the powder reaching the surface amounts to 60 %.

In Germany they use the one-side [15, 16] nozzle attachments with hoses of large diameters, from a fire extinguisher to the attachment, which ensure the intensity of fire suppression at a lower pressure in the body of a fire-extinguishing device by increasing the diameter of the hose and the housing of the fire extinguisher, thereby reducing pressure at the outlet of the powder to 0.01–0.015 MPa. A disadvantage here is the poor maneuverability of operator's actions associated precisely with the diameter of the hose and their small length, as well as a large amount of the powder left in the hoses.

Extinguishing magnesium [17] by a fire-extinguishing powder based on graphite and using a discharge nozzle damping attachment with a one-side ejector and a prolonged housing ensures that 50–70 % of the powder reaches the surface, which does not meet requirements to modern firefighting: losses of a fire-extinguishing powder should not exceed 15 %. 10 % is the permissible residue in the body [DSTU 3675-98], up to 5 % account for the powder remained in pipes, for errors in measurements, for the operator's fire extinguishing experience.

In [14], authors have increased the length of the ejector's casing and managed to attain a result of 65–70 % of powder reaching the fire site at the same pressure.

Fires and explosions that occur as a consequence of ignition of magnesium and its alloys are a relevant issue that must be solved, by developing effective techniques and means for extinguishing such classes of fire taking into consideration their special features. An analysis of available scientific literature reveals that at present there are no effective techniques and equipment that would make it possible to extinguish the fires of class D rapidly and with small losses.

The main drawback of existing equipment is the small amount of the powder that gets to the surface of a burning metal, without fanning the fire and metal shavings. The reason for this is the high motion speed of powder. Pressure in the fire-extinguishing device's body should be high enough to enable the aeration of the powder and its transportation over considerable distances; at the outlet, powder must move in a directed and smooth manner, thereby intensively covering the surface.

Earlier studies, when addressing a decrease in the motion speed of a fire-extinguishing powder, did not examine two-sided damping attachments and the movement of components of a bi-phase medium: gas–powder. They did not employ a software package designed for solving applied problems in the field of aerohydrodynamics by simulating appropriate processes – friction between a particle and a solid surface; non-perfect repulsion of particles from a solid surface; collision of particles and friction against the turbulent flows of gas.

3. The aim and objectives of the study

The aim of this study is to improve the design of a discharge nozzle damping attachment so that it would make it possible to increase the amount of powder that reaches the object under fire, by modeling processes in the nozzle attachment and by verifying experimentally the results obtained.

To accomplish the aim, the following tasks have been set:

- to analyze existing discharge nozzle damping attachments for suppression of fires of class D and the techniques to reduce motion speed of the powder that exits the attachment;
- to model the processes that occur in the two-sided discharge nozzle damping attachments and to define the optimum design of a discharge nozzle damping attachment;
- to verify experimentally the adequacy of the modeled processes in discharge nozzle damping attachments.

4. Analysis of existing discharge nozzle damping attachments for the suppression of fires of class D and techniques to reduce motion speed of the powder exiting the attachment

The study involved two stages:

1) mathematical modelling of powder feed from damping attachments of different designs,

2) experimental extinguishing of the model fire of class D.

In order to study a discharge nozzle damping attachment, we have used the software package COSMOSFloWorks [18], intended to solve applied problems in the field of aerohydrodynamics and heat transfer by simulating the appropriate physical processes. The software COSMOSFloWorks is a fully integrated application of the CAD-system SolidWorks. The software COSMOSFloWorks can be effectively used to calculate the force (stationary and nonstationary) interaction between a solid body and the flow of fluid (gas) in the case of mutual motion. It takes into consideration the influence of different physical factors on the motion of a fluid environment. The software is employed to solving problems on heat exchange, the motion of solid and/or liquid particles in a gas flow.

A mathematical model is based on geometric design of an actual engineering object in the environment of SolidWorks with the subsequent automated exchange of the required information. The movement and heat exchange in fluid environment is modeled by using the Navier-Stokes equations, which describe in the non-stationary form the laws of preservation of mass, pulse and energy of this environment. In addition, the equations of a fluid environment state are applied, as well as empirical dependences of viscosity and thermal conductivity of the environment components on temperature.

In order to solve a problem, a continuous non-stationary mathematical model is discretized in terms of both space and time. To this end, all the estimated region is covered with a grid whose cells' edges are parallel to the coordinate planes in the Cartesian coordinate system. The grid is generated automatically with a possibility to influence dimensions of the cells in order to improve the accuracy of the calculation. Calculations are performed using the method of finite volumes.

Of special interest for our case are the dual-phase media, namely the flow of gas with solid particles. Two-phase flows of the environment with liquid or solid particles are modeled as the motion of these particles in a steady flow of gas. That is, a mathematical model is based on the assumption on that the force and thermal effect of particles on the movement of gas is insignificant. This assumption holds only in the case when the mass concentration of particles in the dual-phase environment does not exceed 30 %. Determination of resistance of the particles is based on the fact that their shape is spherical. Temperature of the particles is determined based on the heat exchange with the environment, and, because

the mass of the particle is constant, its size does change. If it is required, one can consider the effect of gravity. The interaction between the particles and surfaces of the solid bodies is modeled as a complete adhesion (drops of a fluid) or as a repulsion (perfect and non-perfect) characteristic of the solid bodies. Based on this, one calculates a trajectory of particle motion. In addition, it is possible to define both the process of adhesion of particles and the erosion of surfaces.

By using a procedure for constructing the models of structures in the programming environment SolidWorks [19], we shall build a model for a known design of the fire extinguisher's damping attachment [4, 7, 8, 12, 13, 20] whose structural diagram is shown in Fig. 1.

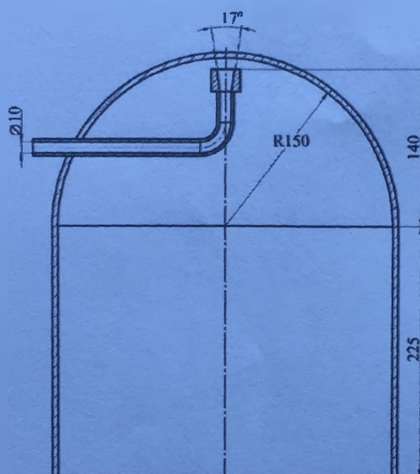

Fig. 1. Structural diagram of the damping attachment for a fire-extinguishing powder feed (estimated model)

A compressed working gas (nitrogen) is fed under pressure of 0.2 MPa to the model's inlet ($\text{Ø}10$ mm) along with a finely-dispersed ($100 \mu\text{m}$) powder of kitchen salt (not exceeding 30 %), thereby creating a dual-phase movable environment whose solid phase does not affect the gaseous phase. The gas that exits a diffuser nozzle attachment hits the upper point of a spherical body, spreads throughout its volume, and leaves (Fig. 2).

Fig. 2, *a* shows that a maximum of the gas speed (316 m/s) is observed at the outlet from the pipe, and then, in the process of its expansion inside the body of a damping attachment, the speed decreases and has rather low values (from 0.5 to 12.5 m/s - Fig. 2, *b*) at the outlet. The chromograms show that the speed of gas in the volume of the body of the damping attachment is uneven, and its propagation (Fig. 3) is turbulent in nature.

Fig. 4 shows the motion trajectories of the solid phase particles in a dual-phase environment (finely-dispersed particles of salt). Fig. 4 shows the speed of solid particles is different from the speed of gas and at the point of maximum values is 245 m/s . At the outlet from the damping attachment's body the speed of particles is different and is in the range from 2.2 to 110 m/s . The cause is demonstrated in Fig. 4. Trajectories of particles with the larger values of speed are straight, and the trajectories of those with smaller values are broken. That is, the speed of a particle is damped as a result of its wander-

ing inside the volume of the damping attachment's body of a fire extinguisher. The reason is the friction between a particle and a solid surface; the non-perfect repulsion of particles from a solid surface; collision between the particles, and friction against the turbulent flows of gas. It should be noted that this process is probabilistic in nature and the particle motion trajectories statistics is permissible in the results of calculations.

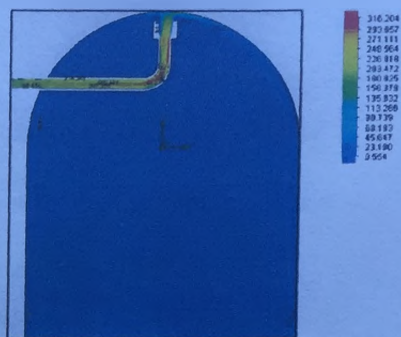

a

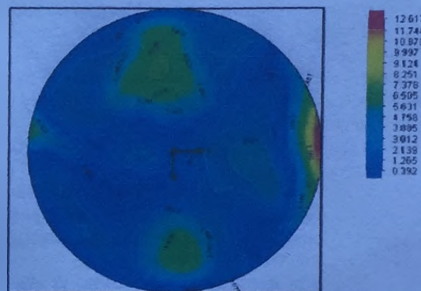

b

Fig. 2. Chromogram of gas leakage: *a* - vertical symmetrical cross-section; *b* - horizontal cross-section at the outlet

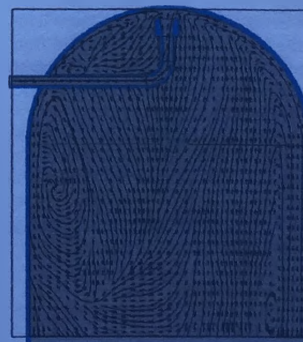

Fig. 3. Trajectories of gas motion inside the body of the damping attachment

If the reasoning on damping the motion speed of the solid phase of the environment is true, we must then change the geometry of a particle ejector. For example, from spherical to elliptical, whose structural diagram is shown in Fig. 5.

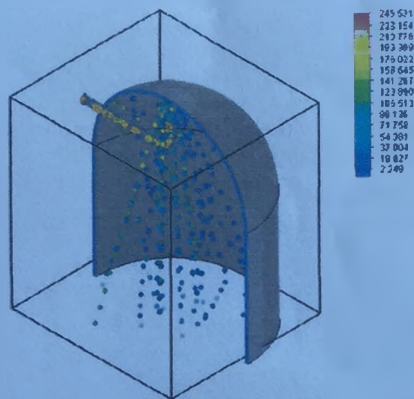

Fig. 4. Trajectories of solid particles motion inside a damping attachment

A particle rejector is based on part of the body of the extinguisher VP-6, namely the elliptic bottom with a cylindrical part of the body, whose hole in the wall hosts an inlet pipe with a diffuser.

Results of calculation of such a model are shown in Fig. 6–8.

Fig. 6, *a* shows the chromogram of leakage of the same gas from a diffuser under a pressure of 0.2 MPa, which hits the elliptic bottom. Fig. 6, *a* shows the maximum value for speed is reduced by 25 %. This can be explained by a decrease in resistance due to a change in the geometry of the wall that the gas flow hits.

Fig. 6, *b* shows a chromogram of leakage of gas from the body of an attachment (cross-section rotated at 90° clockwise) in its bottom part. The chromogram shows that the maximum speed value (45 m/s) is almost four times higher than in the previous case, and the flow of gas is structured in speed relative to the wall.

The character of gas leakage is turbulent, as evidenced when examining its motion trajectories (Fig. 7).

However, studying the movement of particles in the solid phase has shown that the speed of the particles is lower and is in the range of 1.6–80 m/s. Fig. 8 shows that the particles are better spread in the space of a damping attachment's body of a fire extinguisher; there are more irregular motion trajectories, the particles that are repulsed from a solid surface travel longer distances and damp more energy as a result of friction between gas and the surface of a discharge nozzle damping attachment's body.

Thus, despite the higher values of gas motion speed, the maximum motion velocity of particles in the solid

phase of the mixture is 27 % less than that in the previous case.

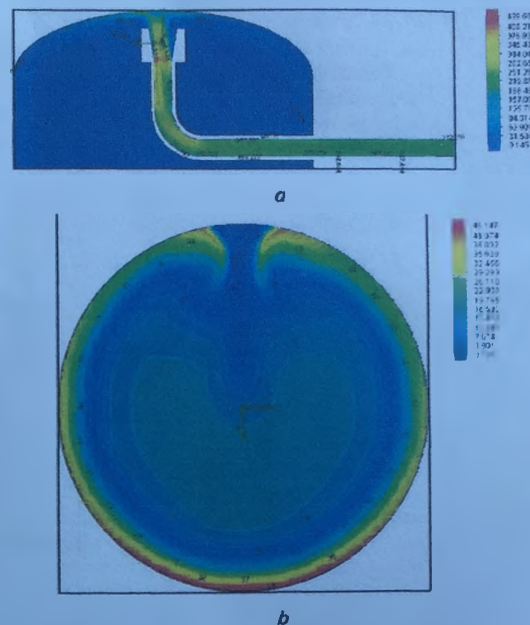

Fig. 6. Chromogram of gas leakage: *a* – vertical symmetrical cross-section; *b* – horizontal cross-section at the outlet

An algorithm for examining the efficiency of structural parameters of the damping attachment is shown in Fig. 1 [12].

We shall determine an optimal pressure when feeding the powder through a damping attachment, an optimal distance from the damping attachment's bottom; we shall examine the diameter and shape of the nozzle attachment; we then shall design an optimal structure of the damping attachment and suppress a model fire. The main elements in the discharge nozzle damping attachment for feeding fire-extinguishing powders in order to extinguish magnesium is the rejector, a nozzle or a diffuser. Earlier studies determined that the powder covers the surface maximally at a nozzle pressure of 0.2 MPa and lower. Diameter of the nozzle or the diffuser (it is better as the powder flow speed additionally decreases) is 12–16 mm. The optimum distance from the end of the nozzle (diffuser) to the surface of the rejector is 10–15 mm [6].

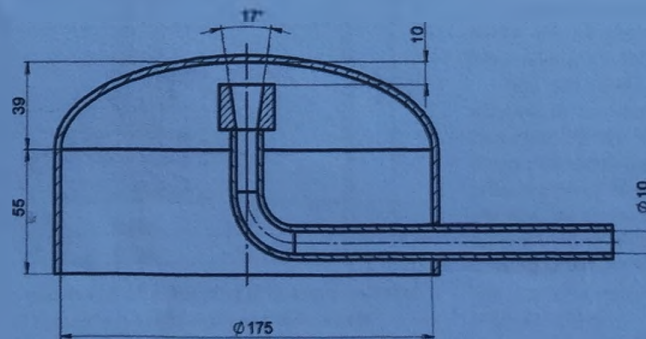

Fig. 5. Estimated model of a damping attachment with an elliptical top



Fig. 7. Trajectories of gas motion inside the body of a discharge nozzle damping attachment

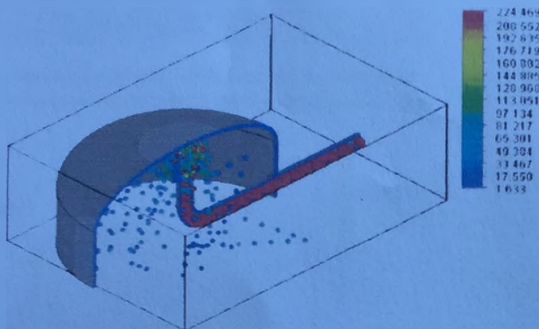

Fig. 8. Trajectories of solid particles motion inside a discharge nozzle damping attachment's body

5. Modelling of processes that occur in the two-sided discharge nozzle damping attachments and determining the optimal design of a discharge nozzle damping attachment

Fig. 9 shows a structural diagram and the estimated model of a damping attachment with an elliptical-top and an additional elliptical mirror with respect to studies considered earlier [12].

Fig. 9 shows the movable dual-phase medium, upon exiting the diffuser, would hit the parabolic mirror (rejector), and, after it, would move upwards, to the elliptical bottom, then, after having been rejected from it, would spread into the environment, and reach the object under fire.

Such a design scheme must be more efficient, that is, a greater deceleration of the solid phase motion is supposed to occur and, as a result, more of it would reach the object under fire.

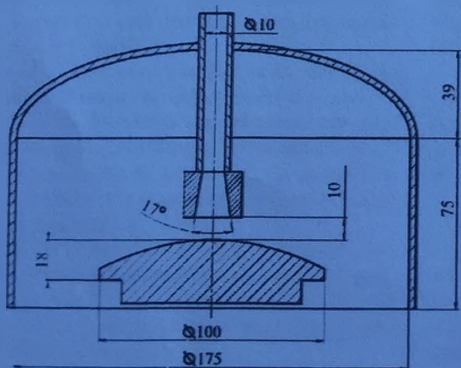
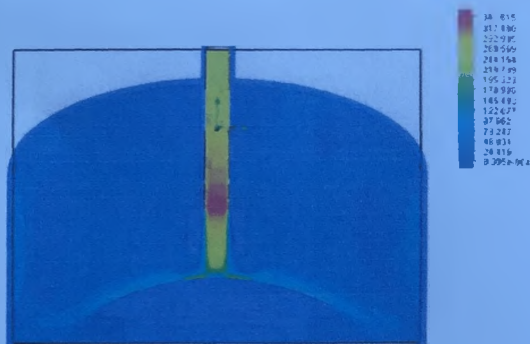
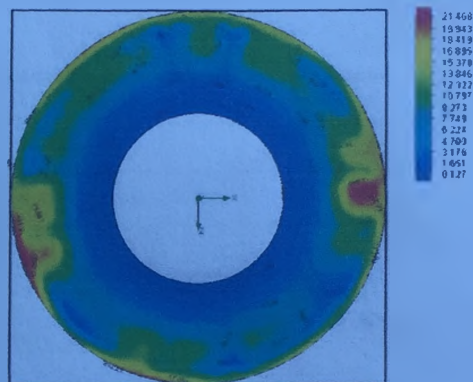

Fig. 9. Estimated model of a damping attachment with an elliptical top and an additional parabolic mirror



a



b

Fig. 10. Chromogram of gas leakage: a – vertical symmetrical cross-section; b – horizontal cross-section at the outlet

Chromograms of gas leakage in both cross-sections of a discharge nozzle damping attachment's body are shown in Fig. 10, a and Fig. 10, b. An analysis of Fig. 10 reveals that the flow of gas is symmetrical and turbulent, and its velocity values slightly decreased compared to the previous variant of the design implementation. The speed of gas especially decreased at the outlet from the body of the discharge nozzle damping attachment – by more than two-fold (from 45 m/s to 21 m/s – Fig. 10, b).

The high and symmetrical turbulence of the gas flow is shown in Fig. 11. The gas flow fairly symmetrically gyrates and demonstrates the well-expressed zones of turbulence, which should lead to the deceleration of motion speed of the solid phase of a fluid environment.

Trajectories of solid particles motion inside the discharge nozzle damping attachment's body with an additional parabolic mirror are shown in Fig. 12.

Fig. 12 shows that particles of the solid phase are sprayed in the space of the discharge nozzle damping attachment's body. The trajectories of motion are formed of many collisions against the surfaces that undergo friction with the twisted gas flow and the surface of the fire extinguisher. As a result, the speed value of particles at the outlet from the discharge nozzle damping attachment's body is in the range of 0.3–20 m/s, which is five times less than in the case of a sphere, and four times less than in the case of a single ellipse.

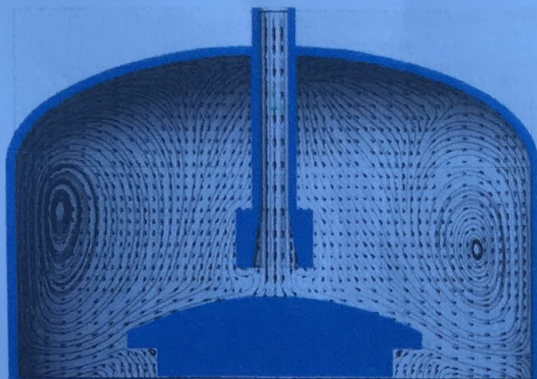

Fig. 11. Trajectories of gas motion inside the discharge nozzle damping attachment's body with an additional mirror

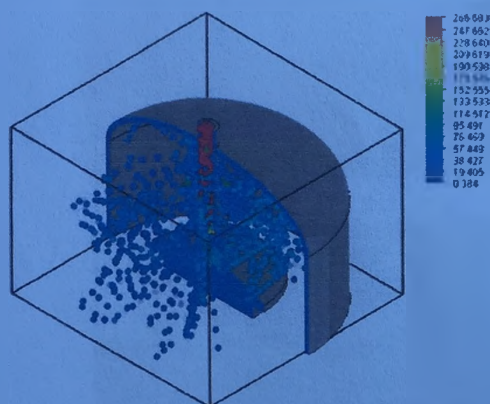

Fig. 12. Trajectories of solid particles motion inside the discharge nozzle damping attachment's body with an additional mirror

6. Experimental verification of adequacy of the simulated processes in the discharge nozzle damping attachments

Experimental study was based on the method for determining the efficiency of powdered agents for extinguishing the model fires of class D. In the fire, we used an alloy of magnesium and pure magnesium in a ratio of 3:1. ML5 (7.5–9 % Al; 0.2–0.8 % Zn; 0.15–0.5 % Mn).

In the course of experimental study, we used metrologically certified equipment and the calibrated measuring means with an accuracy of 0.01 g.

The criterion of the best choice is, first of all, the weight of the powder, which reached the object under fire, and the time of powder feed. To determine the optimum structural parameters of the damping attachment, we conduct a study under field conditions (without extinguishing magnesium alloys) in order to establish the amount of powder that reaches the object of fire suppression.

A schematic of the installation to explore structural parameters of the damping attachment is shown in Fig. 2 [12].

With respect to results from studies [4, 9, 10, 21], we propose carrying out an experiment under laboratory conditions in line with the following procedure:

- check the integrity of hoses and pipes by external examination;

- fill the fire extinguisher's body with 1 kg of the fire extinguishing powder;

- mantle the installation to determine the amount of a fire extinguishing powder that reaches an object of fire suppression, magnesium burning, or similar substances, and conduct the experiment in line with [12].

Each experiment is repeated 3 times. Results of experiments that differ by more than 15 % are disregarded.

The tests were conducted at different pressures, different attachment's diameters, and different distance to the surface of a damping attachment, as well as the shape of the attachment (a direct nozzle or the diffuser) [12].

The best results were obtained at a distance of the diffuser to the surface of a damping attachment of 1 cm, diameter at the outlet from the diffuser is 16 mm, Table 1. Pressure in the extinguisher's body is taken to equal 1 MPa. This is the mean value of pressure at which a fire extinguisher operates longest.

Table 1

Results of experimental research using a one-sided powder repulsion

1	P (pressure)	Mean value at a pressure of 1 MPa
2	Total weight, kg	1
3	Duration t , min.	0.3
4	Mass of the powder that reached an object of fire suppression, G, kg	0.63
5	Mass velocity of the powder reaching deco V_m , kg/s	3.5×10^{-2}
6	Remaining powder in a cylinder, kg	0.022

It follows from an analysis of Table 1 that the value for pressure during experimental research differs significantly (by five times) from the estimated one. This is explained by work spent for the transportation of the powder. When blowing the model from a cylinder of compressed gas without powder, the mean pressure value was approximately 0.2 MPa. This is the value for pressure that was assigned for the estimation models. The boundary concentration of powder in the model is taken such that it does not affect the process of gas flow; only the gas affects the motion of a solid phase. These are very small concentrations (max up to 30 %). However, under actual conditions, we take the maximum amount of powder, thereby effectively extinguishing the fire. That does affect the motion of gas, which we unfortunately cannot consider in the models from the software environment COSMOSFloWorks. We can only state the fact – the resistance to gas flow inside the pipe increases by five times.

Experimental study into a fire extinguisher with a damping attachment whose structure is composed of an elliptical bottom with a cylindrical body and a parabolic mirror was conducted under the previous conditions. Research results are given in Table 2.

Results in Tables 1, 2 demonstrate that the surface of deco of 0.4×0.4 m received, with a one-sided rejector, 0.63 kg of powder, while with a two-sided rejector, 0.92 kg with 0.022 kg remaining in the cylinder. That is, in the second case, the object did not receive only 6 % of the powder.

Fig. 13 shows the process of extinguishing the fire by using the experimental sample of a fire extinguisher with a one-sided rejector and the designed damping attachment with two working surfaces.

Table 2

Results of experimental study with a two-sided powder retractor

1	P (pressure)	Mean value at a pressure of 1 MPa
2	Total weight, kg	1
3	Duration t , min.	0.31
4	Mass of the powder that reached an object of fire suppression, G , kg	0.92
5	Mass velocity of the powder reaching deco V_m , kg/s	4.95×10^{-2}
6	Remaining powder in a cylinder, kg	0.022



a



b

Fig. 13. Extinguishing the fire using an experimental fire extinguisher with a damping attachment:
a – one-sided retractor; b – two-sided retractor

Notable is the compactness of a powder jet and its smooth spreading. The powder evenly covers the burning surface. There are no burnouts upon fire extinguishing over the entire surface. When putting out a model fire using a one-sided retractor, the fire was suppressed in 20 s; when using a two-sided retractor, the fire was extinguished in 7 s.

7. Discussion of results of choosing the two-sided retractor for extinguishing of fires of class D

Results of the experimental study, given in Table 1 (weight of the powder at an object of fire suppression when using a one-sided retractor in the damping attachment is 0.63 kg) and Table 2 (weight of the powder at an object of fire suppression when applying a two-sided retractor is 0.92 kg), reveal that the weight of the powder at the burning surface increased by 0.29 kg. The weight of the remaining

powder on deco increased by 31.5 %, indicating a significantly better efficiency of the design of a damping attachment in line with the structural scheme with two retractors of the solid-phase – an elliptical retractor with an additional parabolic mirror. The same results are shown in Fig. 5–8, 10–12.

This design is more complicated than the known one, but it produces a better result in the fire suppression of light metals. Duration of fire extinguishing is shorter by 2.9 times. Our development could be used when designing the stationary and portable fire extinguishing systems for light metals and alloys, including incendiary grenades under condition of a proper selection of the powder. We have achieved positive results during field tests of the discharge nozzle damping attachment on a model fire when burning shavings of magnesium alloys.

When blowing the model from a cylinder with compressed gas without powder, the mean pressure was approximately 0.2 MPa. This very value of pressure was assigned for the estimation models. The boundary concentration of powder in the model is taken to be such that it does not affect the process of gas flow; only the gas affects the motion of a solid phase. These are very small concentrations (max up to 30 %). However, under actual conditions, we take the maximum powder, thereby effectively extinguishing the fire. That does affect the motion of gas, which cannot be considered in the models from the programming environment COSMOSFloWorks. Thus, we can state the fact – the resistance to gas flow inside the pipe increases by five times.

Using a discharge nozzle damping attachment is effective for stopping the burning at fires of class D at an early stage. The limitation of this structure is in that it is applicable to suppressing the large-scale fires of light metals.

When designing a discharge nozzle damping attachment, it is necessary to take into consideration the requirements to a material that a nozzle is made from; a material must have a high melting point and be light. That makes it possible to longer operate in a zone of high temperatures.

8. Conclusions

1. Chromograms show that the speed of gas in the volume of a damping attachment's body with a one-sided retractor is uneven, and its propagation is turbulent in nature. As revealed by the simulation of a discharge nozzle damping attachment with an elliptical bottom, its application is more efficient than the spherical one. Despite the higher values for the velocity of gas motion, the maximum motion velocity of particles in the solid phase of the mixture is 27 % lower than that in the previous case. Pressure in a fire-extinguishing device's body should be high enough to enable the aeration of the powder and its transportation over long distances, and at the outlet the powder must move in a directed and smooth manner, intensively covering the surface.

2. We have modelled the powder feed from discharge nozzle damping attachments of different designs. It was established that the trajectories of an environment motion are formed from many collisions against surfaces under friction against the twisted gas flow and the surface of a fire extinguisher. As a result, the value of particle velocity at the outlet from the discharge nozzle damping attachment's body is in the range of 0.3–20 m/s, which is five times lower than in the case of a sphere and is four times lower than in the case of a single ellipse. We proposed the discharge nozzle damping attachment to feed a fire extinguishing powder to suppress

fires of class D with two working surfaces – an elliptical top and a parabolic rejector.

3. Adequacy of the mathematical model has been experimentally tested using a physical model, in the form of a damping attachment for feeding a fire-extinguishing powder, in order to extinguish magnesium fire, with two working surfaces – an elliptical top and a parabolic rejector. The amount of powder that reaches an object of fire suppression exceeds 0.920 kg, when totally used 0.978 kg, which is larger than 90 % of the fire-extinguishing substance spent for fire extinguishing. A damping attachment with two working surfaces is more efficient than the previous damping attachment with a one-sided rejector with one working surface, by 30 %, in terms of the amount of powder that reached a combustion zone. That improves the efficiency of fire suppression, makes it possible to cover a burning surface with a greater layer of

the powder, preventing the fanning of chips from the surface of a burning metal. Duration of extinguishing of a model fire decreased from 20 s to 7 s with the increased amount of powder at the burning surface.

The mathematical model is based on the geometric design of an actual engineering object in the programming environment SolidWorks with the subsequent automated exchange of the required information and makes it possible to design a variety of discharge nozzle damping attachments to suppress fires of class D.

The proposed procedure for estimating the efficiency of a discharge nozzle damping attachment with determining the amount of a fire-extinguishing powder that reached a deco size of 0.4×0.4 fed from a fire extinguisher with a charge of 1 kg through the appropriate discharge nozzle damping attachment could be used for testing the nozzle attachments.

Reference

1. Problemy hasinnia mahniu ta yoho splaviv / Kovalyshyn V. V., Mirus O. L., Marych V. M., Kovalyshyn Vol. V., Lozynskiy R. Ya. // Zbirnyk naukovykh prats LDU BZhD. 2016. Issue 28. P. 58–63.
2. Potężny pożar fabryki PolMag w Olszowej. Płonię 47 ton magnezu. URL: <https://nto.pl/poteczny-pozar-fabryki-polmag-w-olszowej-plonie-47-ton-magnezu/ar/8962865>
3. Magnesium-Brand richtet bei Sonneberg Millionenschaden an. URL: <https://www.thueringer-allgemeine.de/web/zgt/leben/blau-licht/detail-/specific/Magnesium-Brand-richtet-bei-Sonneberg-Millionenschaden-an-1529078490>
4. Optimization of the dry chemical powders' composition for class D1 fires extinguishing / Marych V., Kovalyshyn V. V., Kyrlyiv Y., Kovalchuk V., Gusar B., Koshelenko V. // Fire Safety. 2018. Issue 32. P. 45–54. doi: <https://doi.org/10.32447/20786662.32.2018.07>
5. Dovidnyk riadivnyk na vypadok vynyknennia nadzvychainykh sytuatsiy z nebezpechnykh khimichnykh rechovyuny. Lviv: «Spulom», 2012. 377 p.
6. Doslidzhennia khimichnykh rechovyv, yak skladnykh vohnehasnykh poroshkiv dlia hasinnia lehkyykh metaliv / Kovalyshyn V. V., Marych V. M., Kyrlyiv Ya. B., Koshelenko V. V., Mirus O. L. // Pozhezhna bezpeka LDU BZhD. 2016. Issue 29. P. 46–56.
7. GOST R 53280.5.-2009. Ustanovki požarotusheniya avtomaticheskie. Ognetushashchie veshchestva. No. 55. Moscow, 2009. 11 p.
8. Gabrielyan S. G. Primenenie argona dlya požarotusheniya struzhki splavov magniya i titana. obrazuyushcheyssa pri obrabotke na stankah s chisl'ovym programmym upravleniem i obrabatyvayushchih centrakh // Pozharnaya bezopasnost'. 2017. Issue 4. P. 45–51.
9. Balanyuk V., Kovalishin V., Kozyar N. Prevention of n-heptan gas mixtures with the help of combined systems of shock waves and volume firefighting substances // ScienceRise. 2017. Issue 11 (40). P. 21–24. doi: <https://doi.org/10.15587/2313-8416.2017.116177>
10. Rakowska J., Radwan K., Ślosorz Z. Comparative Study of the Results of the Extinguishing Powder Grain Size Analysis Carried out by Different Methods // BiTP. 2014. Vol. 34, Issue 2. P. 57–64. doi: <https://doi.org/10.12845/bitp.34.2.2014.5>
11. Balaniuk V. M., Koziar N. M., Harasymuk O. I. The usage of gas and aerosol powder extinguishing mixtures for protection of incendiary mixtures // ScienceRise. 2016. Vol. 5, Issue 2 (22). P. 10–14. doi: <https://doi.org/10.15587/2313-8416.2016.69333>
12. Vplyv nasadok-zaspokoiuvachiv na efektyvnist hasinnia pozhhez klaviv D1 / Kovalyshyn V. V., Marych V. M., Mirus O. L., Lozynskiy R. Ya., Husar B. M., Bortnyk M. Ya. // Visnyk LDU BZhD. 2018. Issue 17. P. 93–101. doi: <https://doi.org/10.32447/20784643.17.2018.13>
13. Antonov A. V., Stylyk I. H. Metody vyprobuvan vohnehasnykh poroshkiv z vyznachennia yikh vohnehasnoi zdatnosti za klasom pozhhezhi D // Visnyk UkrNDIPB. 2013. Issue 2 (28). P. 242–248.
14. CANNLC-S508-M90, Standard for the Rating and Fire Testing of Fire Extinguishers and Class D Extinguishing Media. Underwriters' Laboratories of Canada, 1996.
15. Ständige Konferenz der Innenminister und –senatoren der Länder, Arbeitskreis V, Ausschuss für Feuerwehrangelegenheiten, Katastrophenschutz und zivile Verteidigung, Evaluierung neuer Löschverfahren bei Metallbränden (Leyröthsberge), 2017.
16. Class D Powder Fire Extinguisher. URL: <https://www.youtube.com/watch?v=-sJ5TlaYPGs>
17. Class D fires – Chubb Pyromet Extinguisher. URL: https://www.youtube.com/watch?v=CTFxCr_Oy94
18. Dudareva N. Yu., Zagayko S. A. SolidWorks 2007 Naibolee polnoe rukovodstvo. Sankt-Peterburg: BHV-Peterburg, 2007. 1328 p.
19. SolidWorks 2007/2008. Komp'yuternoe modelirovanie v inzhenernoy praktike / Alyamovskiy A. E., Sobachkin A. A., Odincov E. V., Haritonovich A. I., Ponomarev N. B. Sankt-Peterburg: BHV-Peterburg, 2008. 1040 p.
20. Ohurtsov S. Yu., Stylyk I. H., Antonov A. V. Analiz metodiv vyprobuvan vohnehasnykh poroshkiv z vyznachennia yikh vohnehasnoi zdatnosti // Visnyk UkrNDIPB. 2013. Issue 1 (27). P. 86–91.
21. Kurepin A. E., Karlik V. M., Sichkorenko L. A. Sposob tusheniya metallov: Pat. No. 2119368 RF. MPK: 6A 62D 1/00 A. No. 97105933/25; declared: 11.04.1997; published: 27.09.1998.